

OpenVPX Backplanes—3U VITA 66, VITA 67,
SOSA Aligned

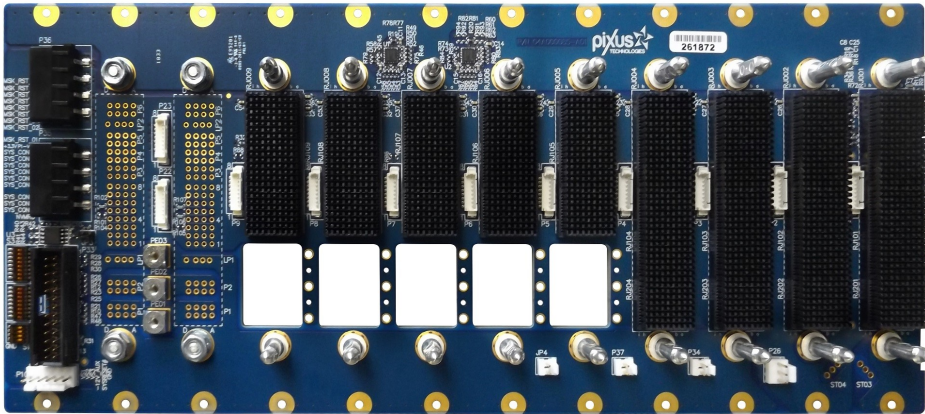

VPX 306, 307 Backplanes



VPX30X KEY FEATURES

- Compliant to latest VITA 65, VITA 66.x and VITA 67.x specifications
- Various OpenVPX & SOSA profiles—contact Pixus for details
- Various slot sizes and configurations available
- 3U backplane design
- 1.0” slot pitch standard, customized sizes available
- Data rate options up to 100GbE with RT-3 high speed connectors
- Selectable rear IO options
- Fast turnaround, superior performance
- Customization available
- Conformal coating optional



OpenVPX is a process that defines system level VPX interoperability for multi-vendor, multi-module, integrated systems environment. The OpenVPX process defines clear interoperability points necessary for integration between Module to Module, Module to Backplane and Chassis. VITA 66 adds optical and VITA 67 adds RF capability to the backplane with multi-position connectors. SOSA aligned versions come in various profiles with SOSA clocking and other optional features.

Pixus has an experienced team of OpenVPX experts and can help you find or create the OpenVPX backplane profile for your application. We offer various data signal speed options and have optional testing services. Pixus is ISO9001:2015 and ITAR registered.

The backplanes are typically 1.0” pitch, but 0.8” pitch is available in some configurations. Contact Pixus for details.

Pixus Technologies can modify this product to meet special customer requirements without NRE (minimum order placement is required).



Specifications

Architecture		
Physical	Dimensions	Height: 3U
		Width: Depending on slot #
	Pitch: 1.0" standard	
	Connectors	MultiGig RT-2 or RT-3 for above 40GbE speeds, VITA 66.x optical, VITA 67.x coax
	Layers	18-24 layers typical
Standards		
VITA	Type	VITA 65, VITA 46 for OpenVPX
	Type	VITA 66 for optical and VITA 67 for RF over OpenVPX
Configuration		
Power		3.3V, 3.3V_AUX, 5V, +/- 12V, +/- 12V_AUX
Environmental	Temperature	Operating temperature: up to -40° to +85°C options
		Storage temperature: up to -55° to +90°C options
	PCB	FR406 or equivalent, Nelco4000-13SI, Meg7 or equivalent for higher speeds (consult Pixus)
	PCB traces	0.5 oz. copper standard
Conformal coating		Upon request (See page 6 selection "J" for available options)
Other		
MTBF	MIL Handbook 217-F @ TBD Hrs.	
Certifications	Designed to meet FCC, CE and EN/UL/TUV certifications where applicable	
Warranty	Two years	
Trademarks and logos	The Pixus Logo is a registered trademark of Pixus Technologies Inc. other registered trademarks are the property of their respective owners. Specs. subject to change without notice.	

Connectors & Signals

Signal Definitions:

Fat Pipe: A channel that is comprised of four links (4 Tx pairs + 4 Rx pairs) is now being referred to as a fat pipe or by use of the x4 nomenclature. 10Gbps capable 10GBase-KX4, 10GBase-BX4, 10GBase-T, PCIe-x4, sRIO-x4, Infiniband-x4

Thin Pipe: A channel that is comprised of two links (2 Tx pairs + 2 Rx pairs) is now being referred to as a thin pipe or by use of the x2 nomenclature. 5Gbps capable 10/100/1000Base-T, 1000Base-BX, PCIe-x2, sRIO-x2, Infiniband-x2

Ultra-thin Pipe: A channel that is comprised of one link (1 Tx pair + 1 Rx pair) is now being referred to as an ultra-thin pipe or by use of the x1 nomenclature. 10GBase-KR, 1GBase-KX, PCIe-x1, sRIO-x1, Infiniband-x1a

SOSA Aligned Profiles

Pixus offers various SOSA routing profiles. Contact the factory for details. Below are a couple of example slot profiles that are common.

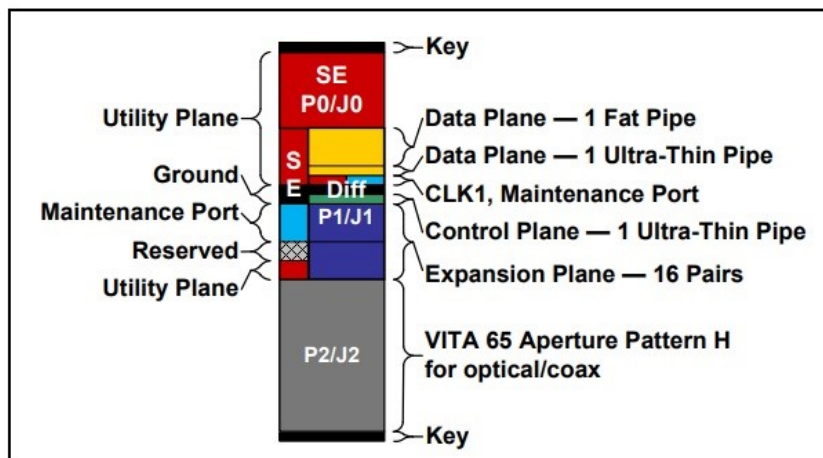

Figure 14.6.11-1 SLT3-PAY-1F1U1S1S1U1U2F1H-14.6.11-n

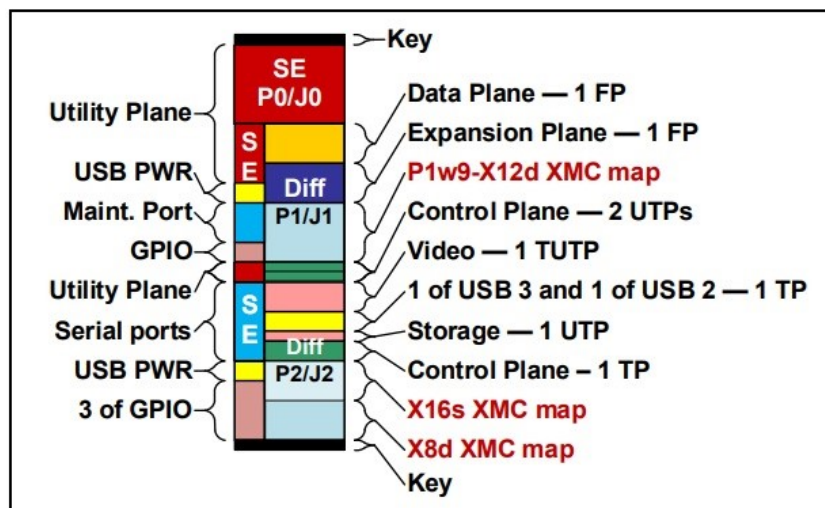
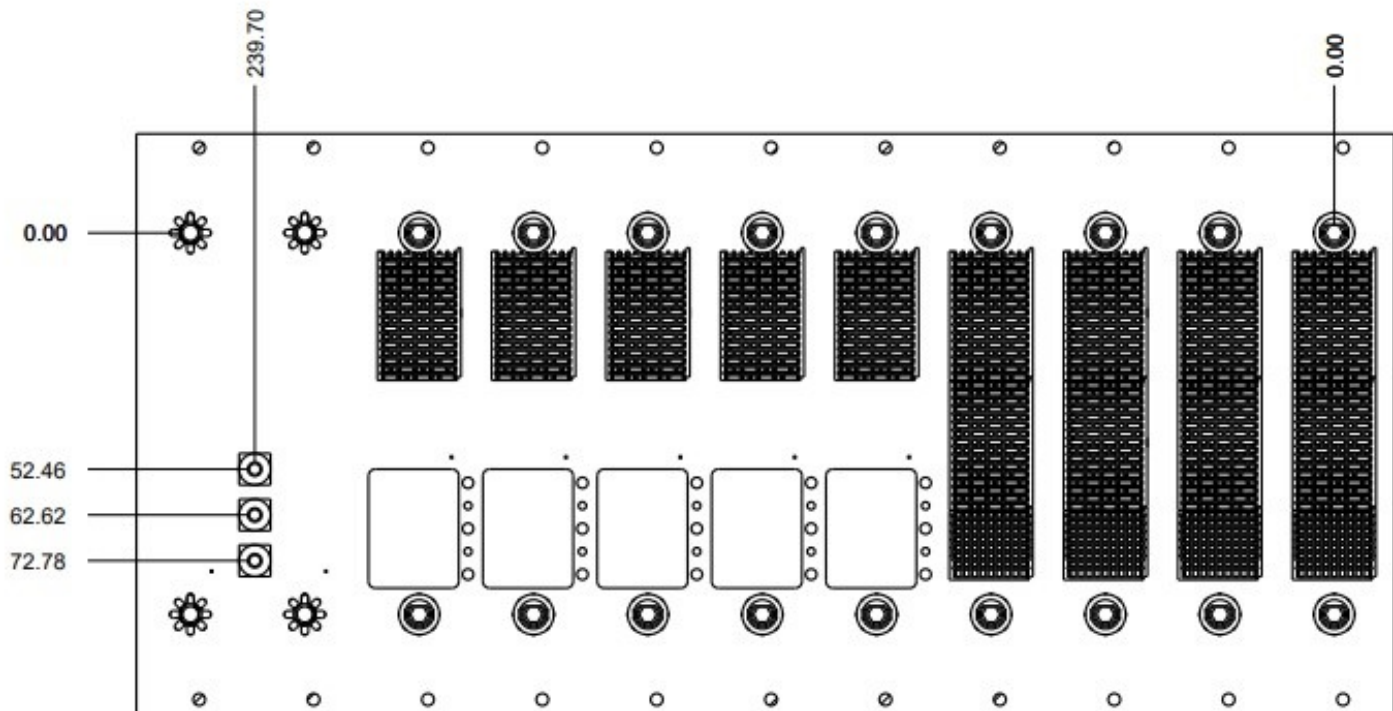
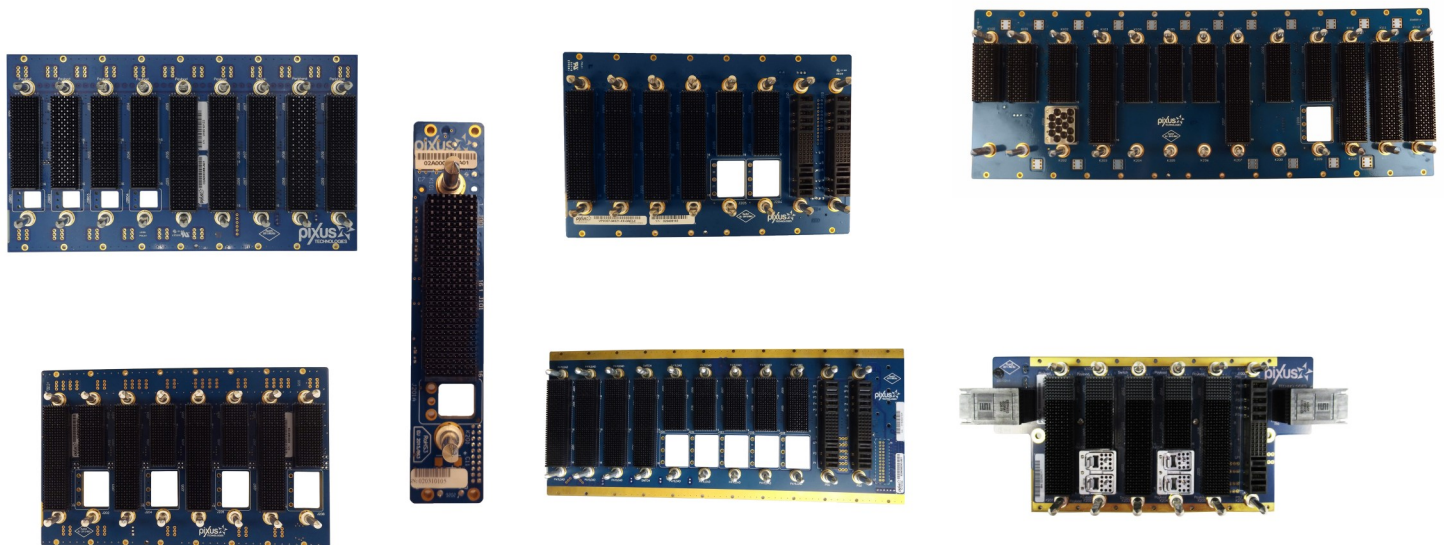

Figure 14.2.16-1 SLT3-PAY-1F1F2U1TU1T1U1T-14.2.16

3U Drawing—9-Slot Example with 1.0” Pitch



Various Examples of VITA 66/67 and SOSA configurations



Ordering Options

VPX306=3U OpenVPX Backplane, VITA 66

VPX307=3U OpenVPX Backplane, VITA 67

VPX30X-ABCCD-EE-FGHI-J

AB = VPX Slots

= 00-16

CC = VITA 66/67 Slots

= 00-16

D = VITA 66/67 Type

0 = VITA 67.1

1 = VITA 67.3/66.5

4 = Mix of types

2 = VITA 67.2

3 = Other

5 = VITA 66.4

EE = Profile Topology

AA = SOSA Aligned

XX = Other

F = Installation

0 = Optical/RF housings/contacts/cables not included (cutouts only)

1 = Optical/RF housings installed, contacts/cables included

2 = Partial installation (custom)

G = Rear IO

A = Full rear IO connectors

X = No rear IO connectors

C = Partially loaded or custom

H = Data Rate

1 = 16.0 Gbaud (PCIe Gen4)

3 = 6.25 Gbaud

5 = 40GbE (4 x ~10Gbps)

2 = 100GbE (4 x ~25Gbps)

4 = 8.0 Gbaud (PCIe Gen3)

6 = Other

I = Power Interface

1 = M3 threaded power element

2 = 1 x VITA 62 PSU interface

3 = Other

J = Conformal Coating

0 = None

1 = Humiseal 1A33 Polyurethane

2 = Humiseal 1B31 Acrylic